



11th International Conference and Exhibition on *Device Packaging*

# Suitability of Copper Wire Bond ICs in Automotive and Other Harsh Environment Applications

Jim McLeish

Dr. Randy Schueller

Mike Howard

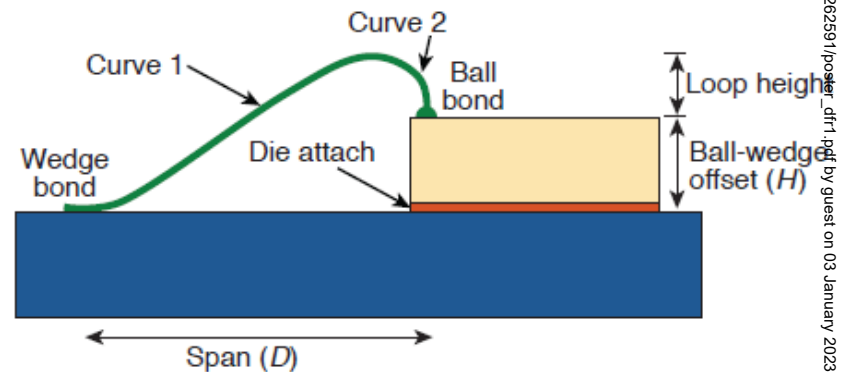

# Traditional Semiconductor Bond Wires

- Wire bonding for semiconductor die to die and die to package terminals connections has traditionally been performed using either aluminum or gold wire
  - Lower cost Al wire for wedge-wedge bonds especially used in power electronic devices but Al is not as versatile for complex package
  - Gold wire with higher ductility provides the ability to make fine bonds and to use a ball and stitch process.

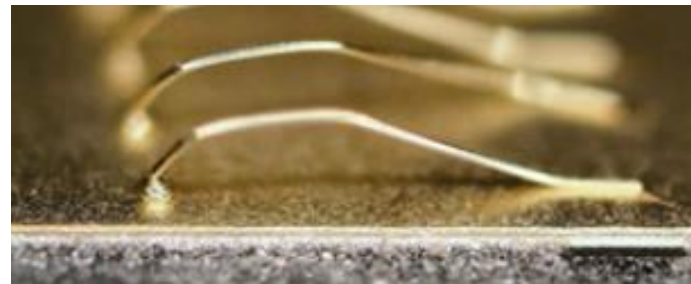
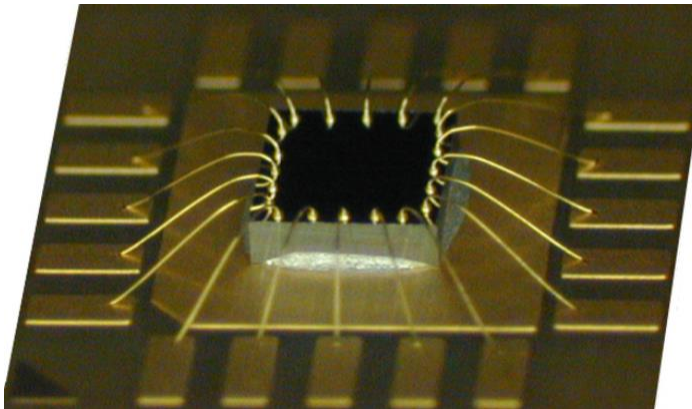
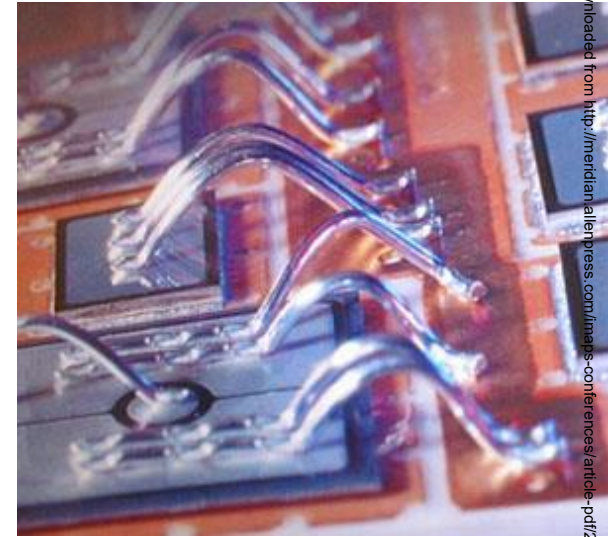

# Motivation for Copper Bond Wires – Gold Price Escalation

- From 1993-2005 Gold prices varied between \$300-\$400/Troy Oz.
- In 2005 Gold prices started to escalate peaking at \$1,800/Troy Oz. in 2011 (~\$1,152/Troy Oz. end of Feb. 2015)
- While copper varied from \$1.5-4.5/Pound (\$0.10-\$0.31/Troy Oz.) (~\$2.67/Pound end of Feb 2015)
- The Gold price escalation drove R&D to develop Copper wire bonding technology in the late 2000's
- Copper Wire Bonded (Cu-WB) ICs successfully, started to appear in production consumer grade ICs in 2010.

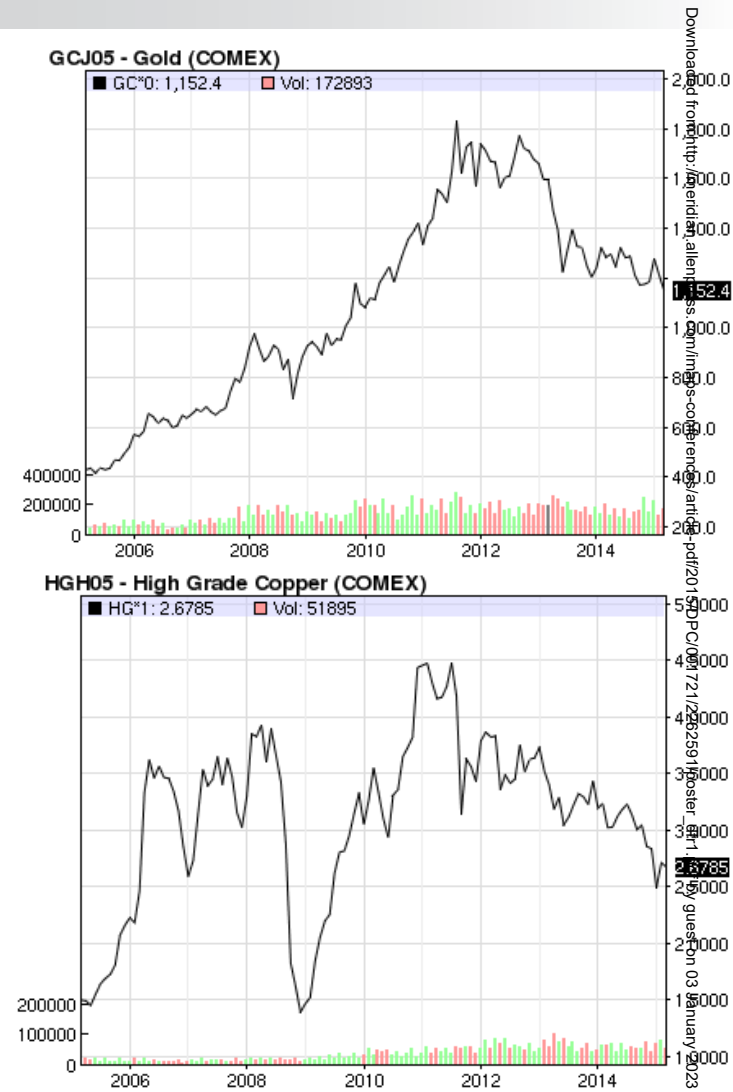
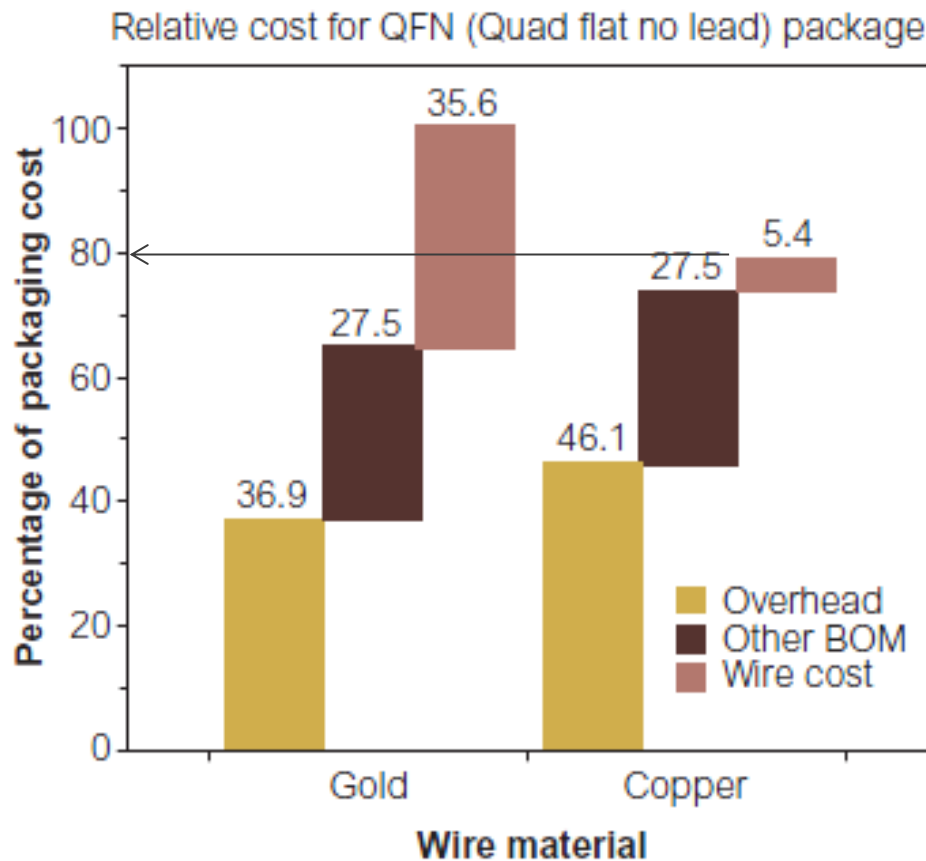

Chart Source: <http://www.nasdaq.com/markets/>

DfR Solutions

# 2008 Cu-WB Migration Rational - Package Cost Breakdown

- Cu WB equipment costs slightly more and throughput is slower
- But lower Cu wire cost more than makes up for both issues
- Rational got stronger as Gold prices continued to increase



Source: L J. Ramos.  
*Copper Wire Manufacturing Challenges.*  
 Semicon Singapore 2008  
 Competitiveness varies with  
 market prices of Gold & Copper

## Cu-WB Current Status

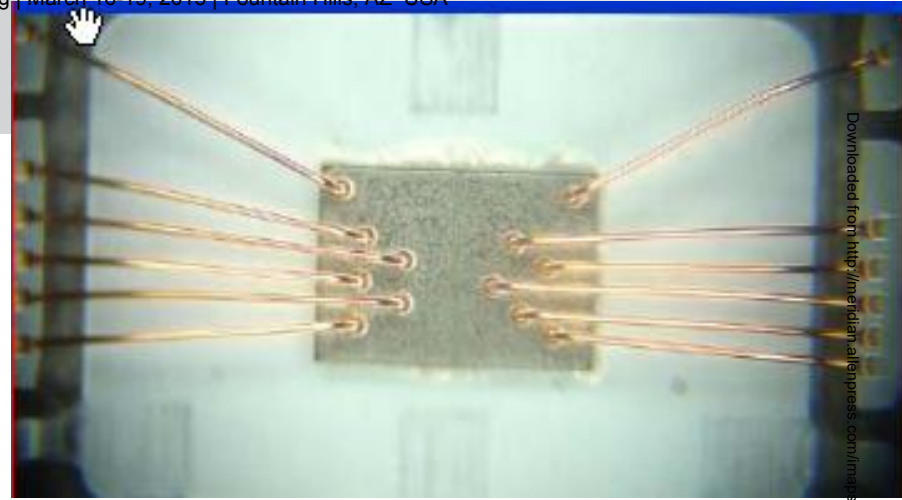

Downloaded from <http://mrl.sagepub.com/journalsPermissions.nav> at 11:22 22 June 2015

- Cu wire is significantly cheaper
- Cu material Properties requires more complex & slower bonding process with tighter process window
- Initially used on small, low cost consumer grade IC (2010)
- Process optimization during this time led to Cu-WBs migrating across IC supplier product line to more Complex ICs
- But still less proven for Harsh Environment, Long Life, High-Reliability applications

# Migration of CU-WB to Automotive Electronics

- 2114 - Cu-WB Component slated to migrate to Automotive Electronics
  - Reliability issues with some Cu-WB components have been detected during the rigorous product validation durability–reliability tests of automotive E/E modules.
  - Components were “Automotive Grade” per Automotive Electronic Council specs.
- In automotive E/E Quality, Reliability & Durability + Safety (QRD+S) over 10-15 years in a harsh environment is essential, along with managing cost in the highly competitive global automotive market.
- Automotive OEMs desire that products be designed right on the first attempt so that budgets & schedules can to be maintained without extra cost & time to find and correct test problems
- OEMs expect robust E/E components the will pass Module Level testing
- Want component levels issues resolved further down the supply chain.

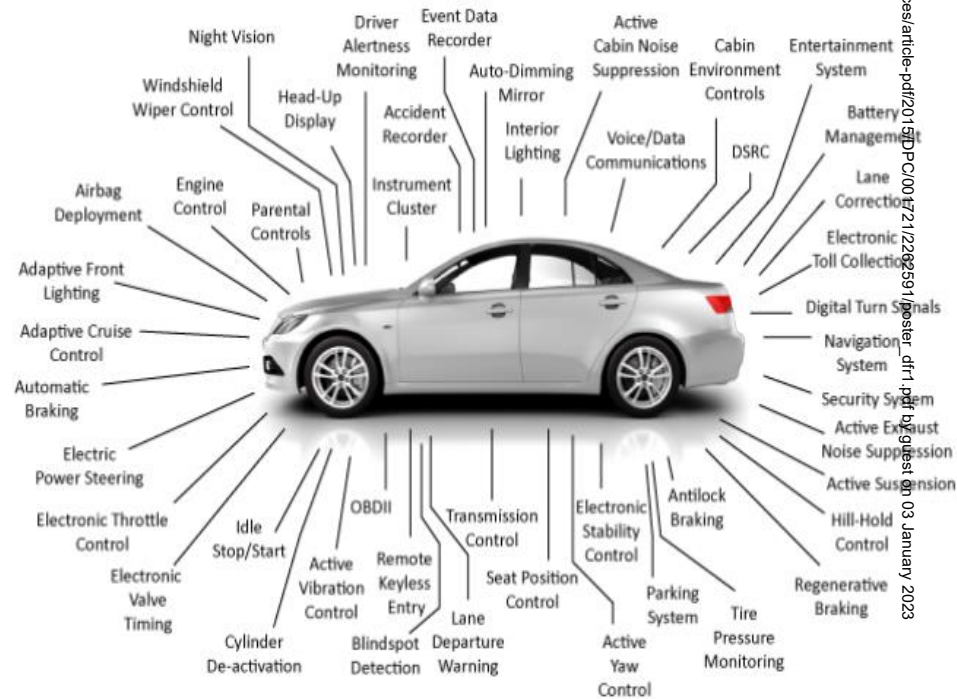

Downloaded from http://meridian.allenpress.com/imaps-conferences/article-pdf/2015/PC/0042/12282591/posser\_dfr1.pdf by guest on 03 January 2023

# Auto Industry Hyper Sensitive to E/E QRD+S after Tragic 2014

- Record 700 recalls of 62 million vehicles, costing billions of \$\$\$
- Many of these issues had reliability aspects, systems functioned for years before failures occurred with safety consequences.
- Others involved not recognizing the safety consequences of product QRD (Quality, Reliability & Durability) capabilities, especially when new technology is involved.
- The Head Line Seemed Endless!

**Detroit Free Press**  
A GANNETT COMPANY

Search  **SUBSCRIBE NOW FOR HOME DELIVERY**

HOME NEWS SPORTS AUTOS BUSINESS LIFE ENTERTAINMENT USA TODAY MORE

**Automakers set recall record and mostly for basic issues**

**Obama asks Congress for dozens more auto-safety investigators**

**Congress Steps In To Investigate General Motors And NHTSA**

**Federal regulators fine Honda \$70 million in safety investigation**

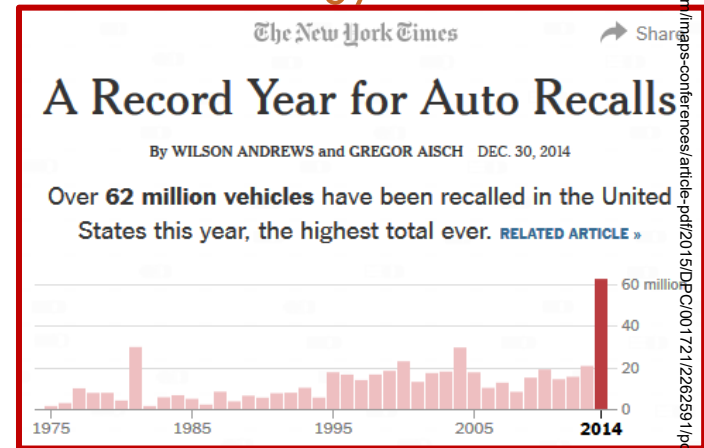

**US Congress probe of deadly defect in GM cars expands**

**It's official: 2014 was a year of record auto recalls**

by Ben Geier @ben\_geier FEBRUARY 13, 2015, 11:00 AM EST **FORTUNE**

**2014: Year of the Most Automobile Recalls Ever**

Tweet 226 8+1 6

Downloaded from http://meridian.allenpress.com/imaps-conferences/article-pdf/2015/DFC/001721/2262591.pdf

# Auto Industry Galvanized After Record Recall Year

Source: <http://www.nytimes.com/2014/12/31/business/a-year-of-record-recalls-galvanizes-auto-industry-into-action.html>

- “Automakers are cleaning up years of defects that previously went undetected or ignored.”
- “What you’re seeing is the makeover of the entire industry.”
- “The auto industry’s intense focus on neglected safety issues has changed the way it approaches even the most basic safety practices.”
- “G.M. has reorganized its sprawling engineering organization and centralized all safety functions.”
- Enhanced E/E safety focus needed as the era of self-driving vehicles approaches
- OEM are questioning and challenging their suppliers to prove every aspect of E/E QRD and Safety
- New Standard - ISO-26262 Function Safety – Vehicle System
  - Defines a demanding, comprehensive, ideal product development and validation processes that are expected to be integrated into automotive product development and validation processes.

DfR Solutions

# Are Cu-WBs Suitable for Automotive & Other Harsh Env./Hi-Rel Applications? (Automotive, Military, Aerospace, Infrastructure, Medical, Space . . . Etc.)

## Key Reliability Physics Considerations & Trade Offs:

Property	Gold (Au)	Copper (Cu)
Elastic Modulus	8.8 Mpa (+ More Ductile)	13.6 Mpa (- Less Ductile)
Tensile Strength N/m <sup>2</sup>	>240 Higher (+ Stronger)	160-200 Lower (- Weaker)
Oxidation	No (+)	Yes (- Oxidation Susceptibility)
Melting Point	1064°C (+Faster Bonding)	1085°C (Slower Bonding)
Work Hardening Rate	Low (+ Bonds Easily)	High (- Harder to Bond)
Electrical Resistance	2.3 uohm-cm (- Higher)	1.7 uohm-cm (+ Lower)
Thermal Conductivity	293 W/mK (- Lower)	394 W/mK (+ Higher)

- Cu has a higher melting point, oxidizes & is harder than gold – Ultra-sonic bonding more difficult & slower
- Copper is weaker & less ductile than Gold – Durability Consequences
- Copper has better electrical & thermal conductivity – Improved E/E Performance



Downloaded from http://meridian.allenpress.com/imaps-conferences/article-pdf/2015/DP/PC/001721/2262591/poster\_dfr1.pdf by guest on 03 January 2013

## Cu-WB QRD+S Concerns

- Initial concern with Cu-WBs is creating a high quality bond.
  - Cu Bonding process challenges and a weak bond or a bond that is insufficient for the application will fail sooner than optimized bonds
- The next concern is **LONG TERM RELIABILITY** in Harsh Environments (mostly for non-consumer HI-REL markets such as automotive & military)
- Primary Concerns:
  - **Temperature cycling**
    - Low cycle fatigue from cyclical thermal expansion-contraction
  - **Temperature/Humidity Endurance**
    - Package Delamination & Corrosion
  - **Elevated Temperature Endurance**
    - Excessive Intermetallic formation

# Typical Ball & Stich Wedge Wire Bond Process

## Ball Bonds

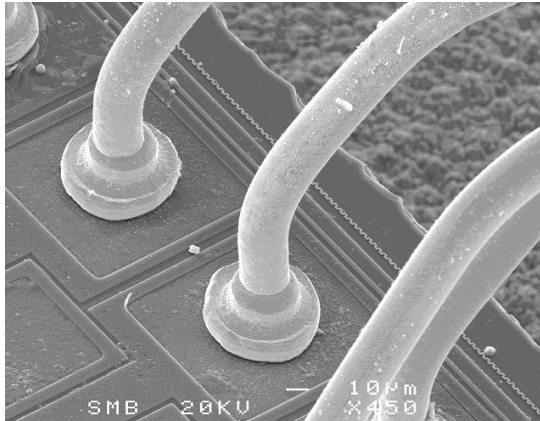

## Wedge Bond

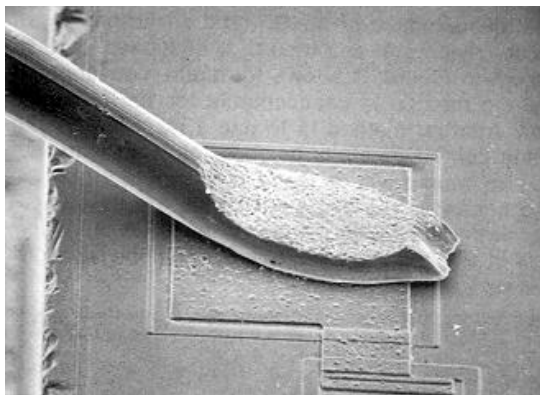

1. The bonding process begins with a threaded capillary.

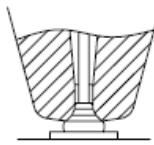

4. Force and Ultrasonic Energy are applied over Time and the Ball Bond is made.

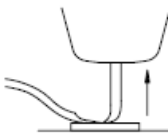

7. The capillary rises with the Wire Clamps off for a specific distance.



10. The EFO forms the next Free Air Ball and the cycle begins again.

2. Electrical Flame Off (EFO) forms the free air ball.

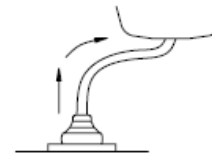

5. The Looping Sequence



8. The Wire Clamps are applied and the wire breaks away from the 2nd Bond leaving a specific tail length.

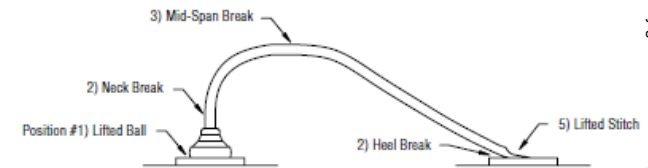

Preferred Failure Modes

- Mid-Span Break (Bond Strength exceeds Wire Tensile Strength)
- Neck Break at Heat Affected Zone (HAZ)
- Heel Break



3. The capillary captures the free Air Ball in the Chamfer Diameter and descends to the Bond Site.

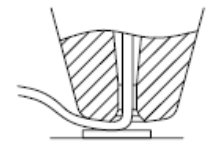

6. Force and Ultrasonic Energy are applied over Time to make the Stitch Bond.

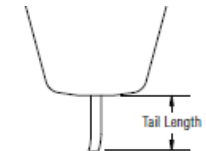

9. The Tail Length after breaking away from the 2nd Bond

Undesireable Failure Modes

- Lifted Stitch
- Lifted Ball

# Cu Bonding Quality & Process Challenges

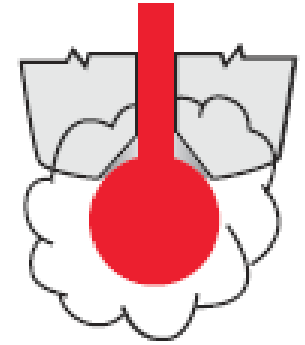

- **Ball Formation & Oxidation**
  - Ball bonding requires heating to melt the wire tip into a very symmetrical, spherical ball, of precise dimensions, that is oxide free (known as the Electronic Flame Off (EFO) process)
    - Since Gold does not oxidize or corrode a gold ball could be formed in air
    - However Copper does oxidize especially under high temperature, Copper oxide on the ball surfaces result in weak, partial bonds prone to fail
      - Because copper readily oxidizes, it has a short shelf life; Cu bond wire must used within one week of package opening.
      - To prevent oxidation during Cu ball formation, a nitrogen (N<sub>2</sub>) inert atmosphere was originally required
      - It was later found that 95% nitrogen & 5% hydrogen (called forming gas) is more effective at preventing Cu oxidation

# Forming Gas Reduces Cu Ball Oxide Formation Better than N<sub>2</sub>

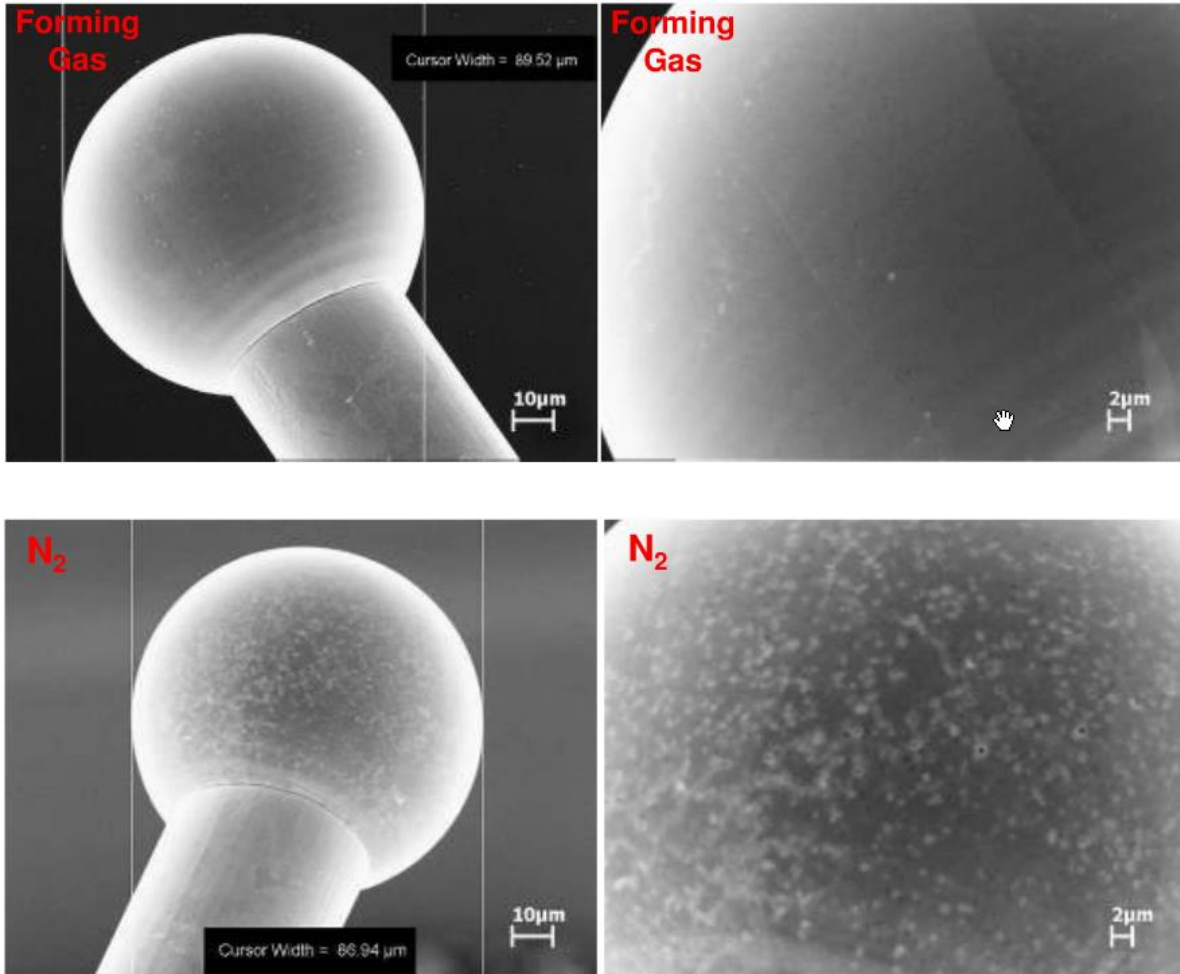

- Less Cu Oxide formation with 95% nitrogen/5% hydrogen forming gas

Ref: Heraeus  
<http://wenku.baidu.com/view/8119b3bafd0a79563c1e72de.html>

# Cu Bonding Quality & Process Challenges

- Preventing pad and die damage & Cu ball bond failure
  - Since CU is harder than gold, more force is required during thermosonic bonding
    - Excessive force can displace bond pad aluminum known as “Aluminum Splash” when bonding forces causes pad aluminum to flow out from under the ball bond or the ball can punch through the pad ”
    - May damage die material or features under the pads.

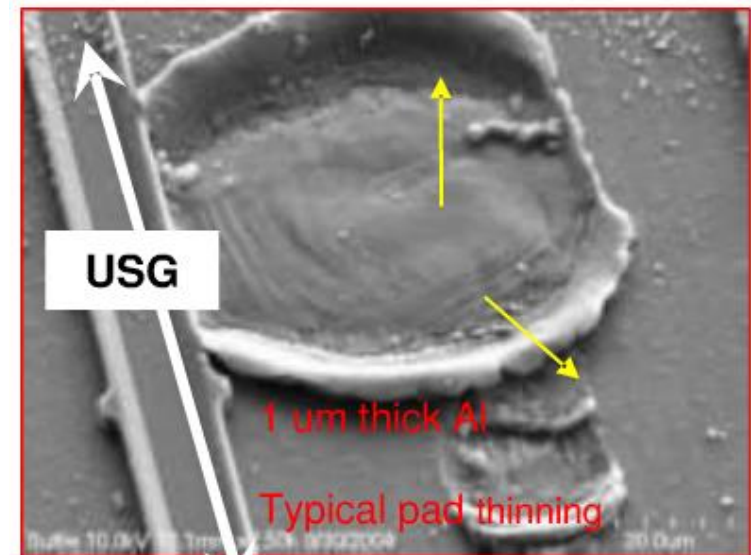
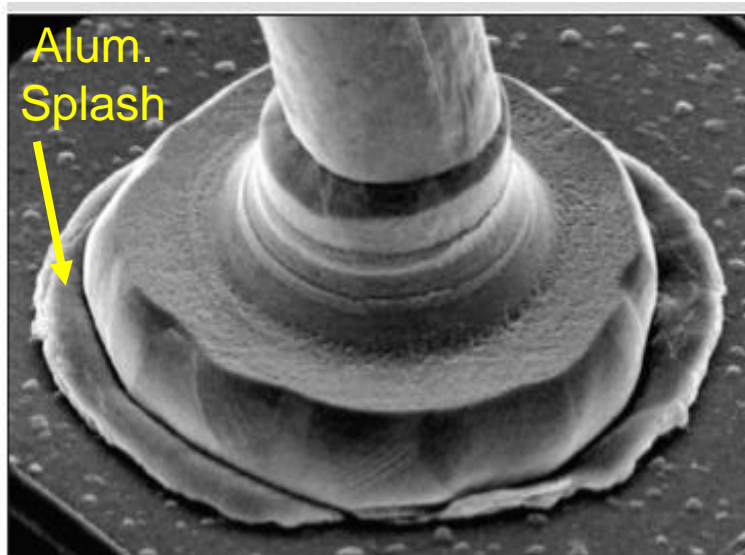

Risk is that remaining Aluminum on pad is too thin.

DfR Solutions

# Cu Bonding Quality & Process Challenges

- Bonding process must be controlled so that  $\geq 0.2\mu\text{m}$  of the original aluminum pad thickness remains for the pad to maintain the strength needed to prevent pad fractures or tearing.
- Can also be mitigated with pads that are thicker than the typical  $1\mu\text{m}$  Al thickness used with gold wire bonds.
- Higher Purity Copper Wire ( $>95\%$  Cu) is softer

# Aluminum Pad Cratering

- Cu bonding typically requires higher force and thermosonic vibration, Wearing through the Al Pad risks damage to the underlying Si & .

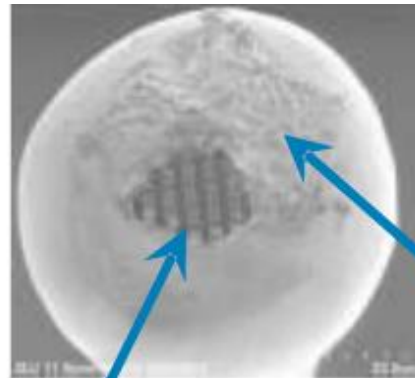

dielectric on bottom of ball

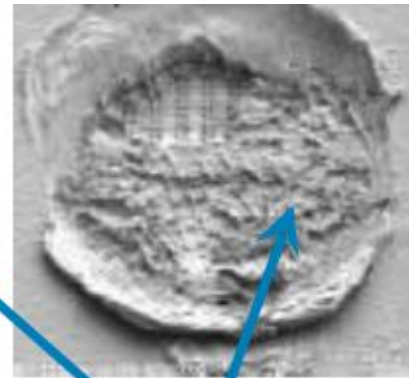

failure mode within aluminum

Si fracture in chip

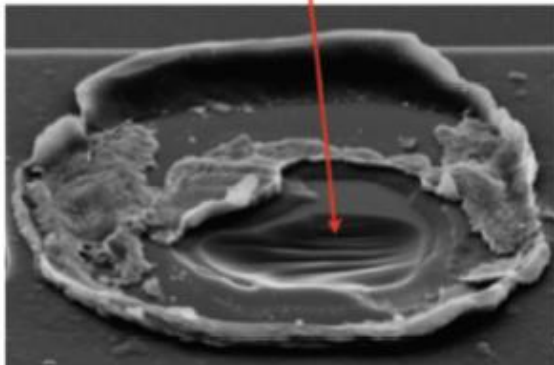

Si from chip

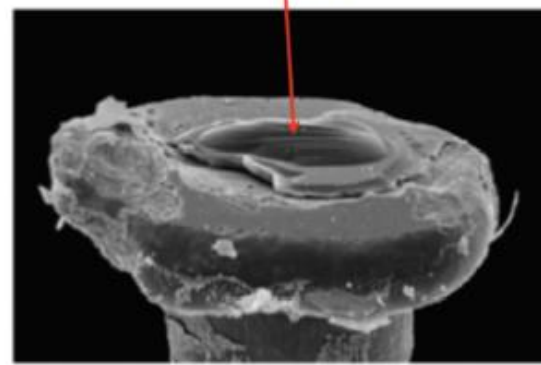

# Other factors that Increase Aluminum Pad Cratering Risks

- The process window for an acceptable ball bond is considerably smaller for Cu compared to Au.
- Cratering can cause immediate or failure or become a latent failure (by initiating a crack that eventually grows to failure or allows metal migration – worst case)
  - With I.C. Designer's desire for miniaturization, placing bonding pads over active circuits features is becoming more common
  - Use of Low K dielectrics which are fragile easily cracked)
  - GaAs die are also more fragile
- Optimization and control of key variables is paramount.
  - **Best QRD achieved with wire bonders specifically developed for Cu-WB**  
**QRD will be lower with Retrofitted Gold WBs**
- Effort to avoid cratering, die cracking or excess Al splash, can lead to overcorrection (too low force/temp/ vibration)
  - This can create weak bonds.

# Long Term Reliability – Thermal Cycling

## Thermal Cycling

- Cu Wire is Weaker and Stiffer than gold
- Loose ICs have passed component level T cycle tests that assess durability-reliability of the thermal expansion-contraction stresses within the component.
- Cu-WB IC failures have occurred on T Cycle testing of automotive E/E modules, believed to be due to additional expansion-contraction stresses from the CTE mismatch of the between the circuit board and & component are transmitted to the wire bonds through the leads.

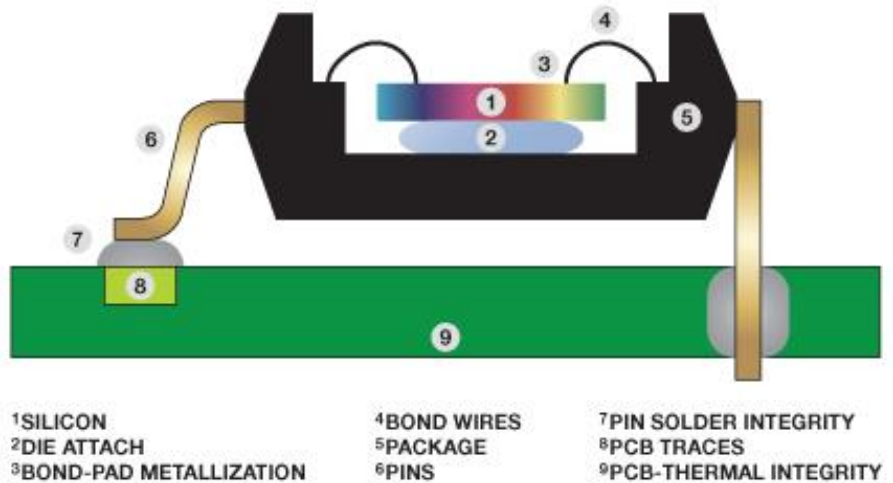
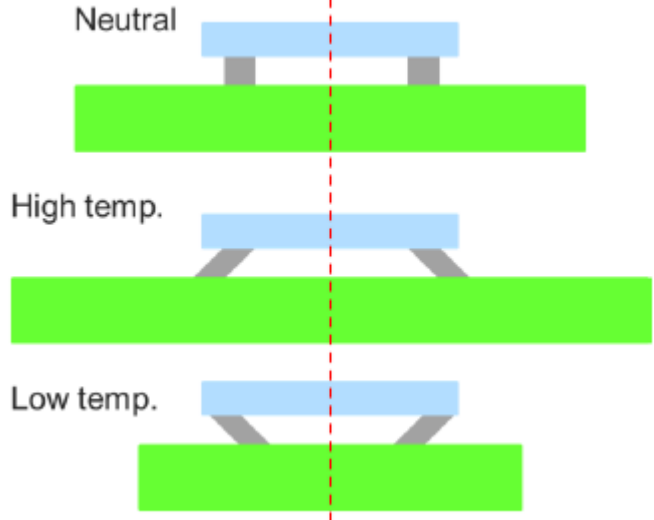
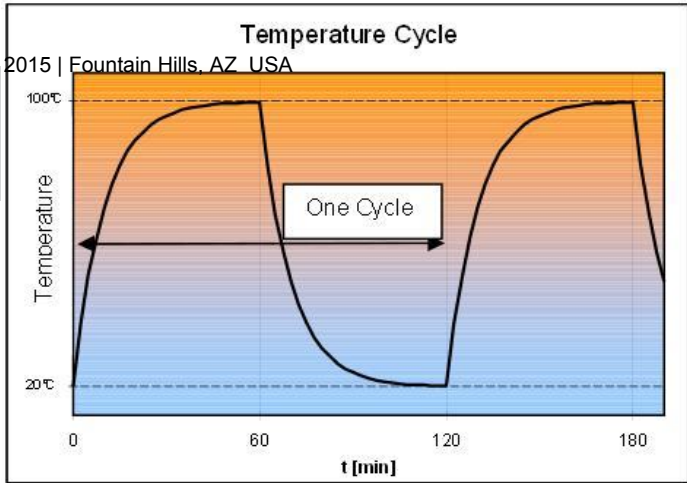

Downloaded from [http://meridian.allenpress.com/imaps-conferences/article-pdf/2015/DP/001721/2262591/poster\\_dfr1.pdf](http://meridian.allenpress.com/imaps-conferences/article-pdf/2015/DP/001721/2262591/poster_dfr1.pdf) by guest on 03 January 2023

# Wire Bonds and Temperature Cycling

- Historically, temperature cycling has not been a major concern with gold wire bonds
- Significant amount of loop height creates low stress in ball and stitch bonds
- With Optimized, Defect Free Cu-WBs similar T cycle Durability is Possible

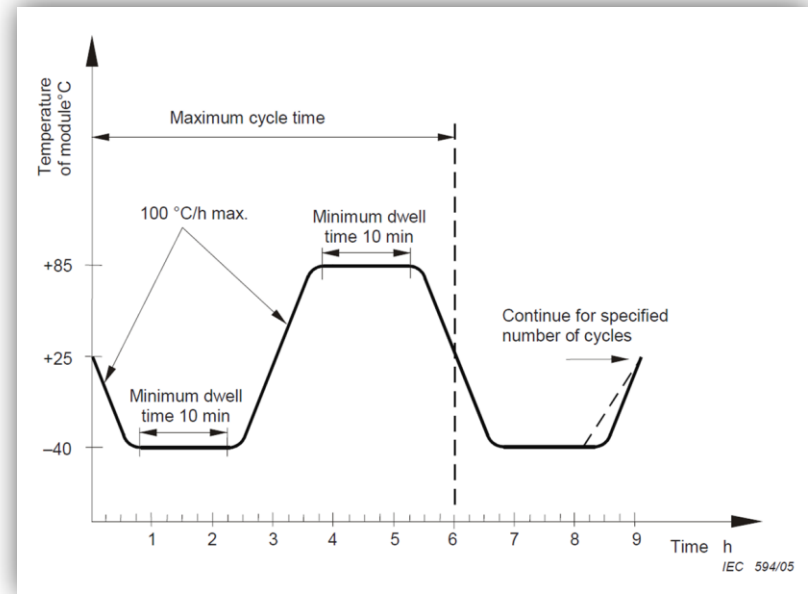
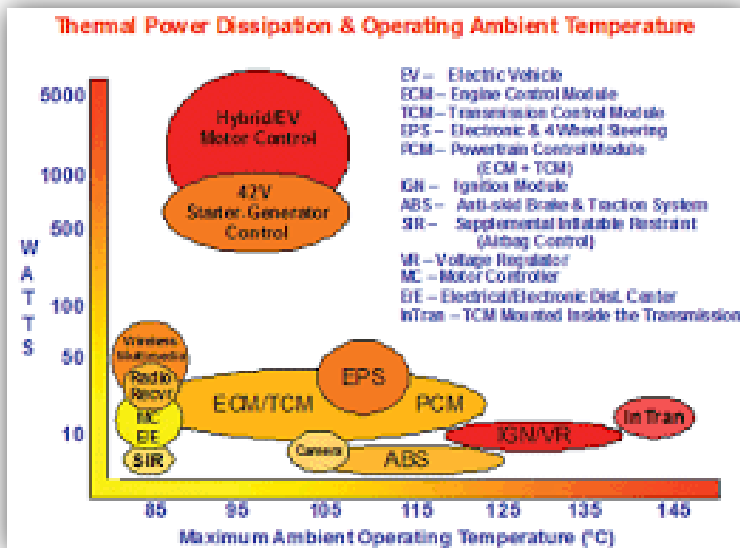

DfR Solutions

# Long Term Reliability - Thermal Cycling Issues

- Cu-WB Module level thermal cycle Issues (known thus far to DfR), have been related to either bond defects or under optimization design issue

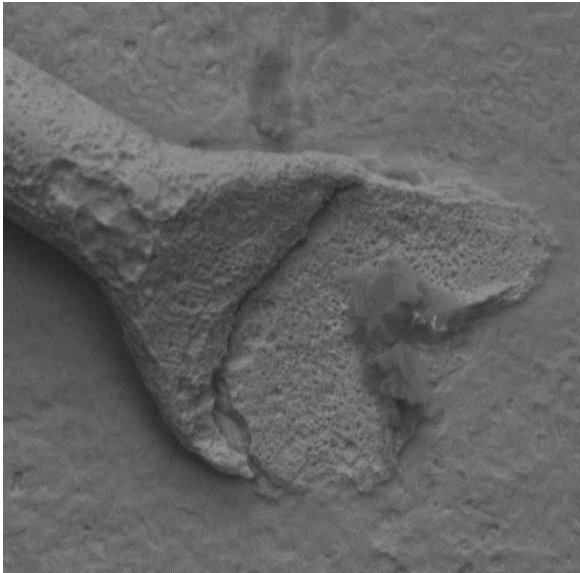

Cu stich broken at a poorly formed “pinched” wedge bond heel (where the wire enter the wedge)

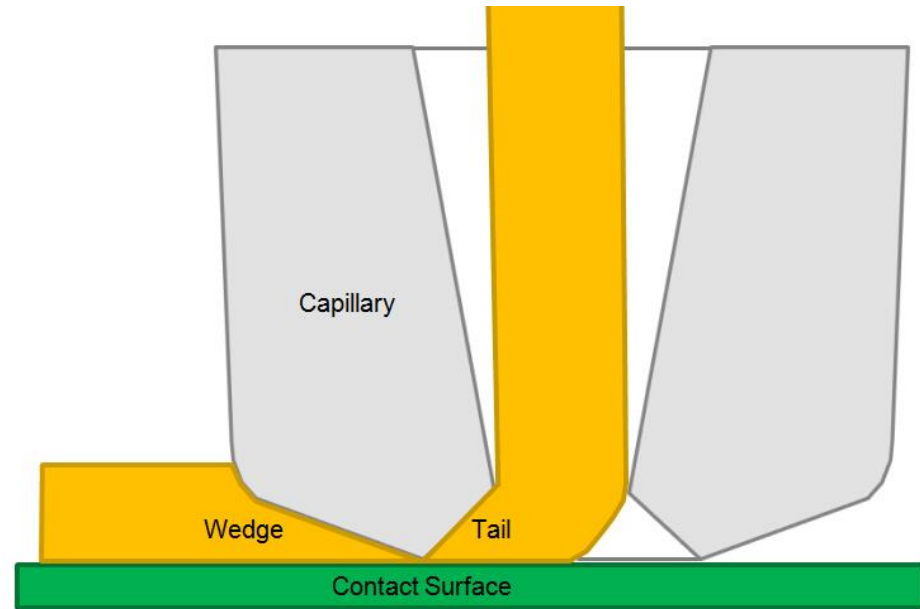

An optimized, non-worn wire bonding capillary head that is sized & shaped to provide an adequate heel weld & a gradual transition back to the wire diameter. Proper calibration & wear monitoring/maintenance is required to prevent excessive flattening & pinch points

DfR Solutions

# Thermal Cycling Durability & Capillary Head Size

- IC Designers typically incorporate the smallest feature possible
- Their desire for small bond pads is contrary to thermal cycling endurance where larger wire bonds result in greater Thermal Cycle durability
  - Wire bond size is determined by capillary head size and geometry
  - Larger bonds require larger bond pads on the IC die

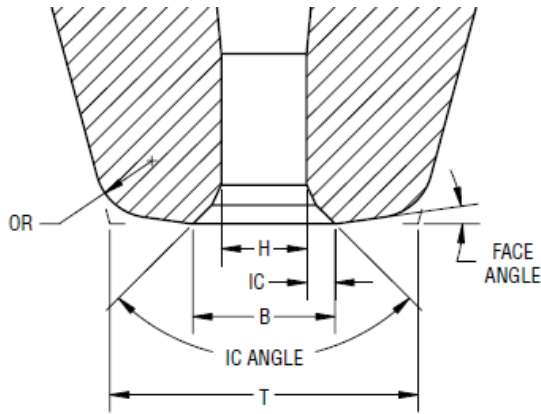

Capillary Tips w/Larger Diameters & Face Angles Keyed to Wire Dia Produce Larger, Stronger, More Durable Wedge Bonds

Similar to IPC Class 1-3 Reliability-Durability Ratings Being Correlated to Solder Joint Size.

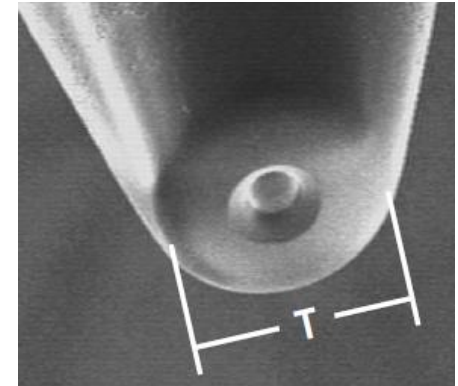

- (T) Tip Diameter ~ Wedge Bond Size
- (H) Hole Diameter ~ Wire Size
- (B) Chamfer Diameter ~ Ball Bond Size
- (IC) Inside Chamfer Length ~ Ball Bond Size
- (IC Angle) Inside Chamfer Angle ~ Ball Bond Size
- (FA) Face Angle ~ Wedge Bond Slope & Heel Thickness
- (OR) Outside Radius – Wedge Bond Size

Full size capillaries for 25-33 $\mu$ m diameter wire have tip diameters from 140-229 $\mu$ m.  
 For tighter packages w/smaller 20 $\mu$ m diameter wire tip diameters as small as 102 $\mu$ m may be needed.  
 With fine pitch applications, tip diameters of 76 $\mu$ m or smaller are available.

# Thermal Cycling Durability & Intermetallic Bonds

- The actual IC pad bond is the result of the weld creating CuAl and AuAl intermetallic compounds.
  - Formation of the proper amount of Intermetallic Compounds (IMCs) optimizes the bonding strength which can be measured with wire pull & shear tests.
  - The CuAl inter-metallic compounds that form the bond need to cover at least 70% of the ball contact area.

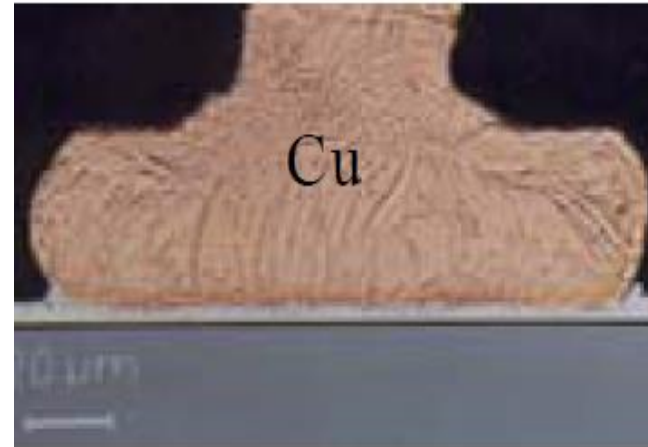
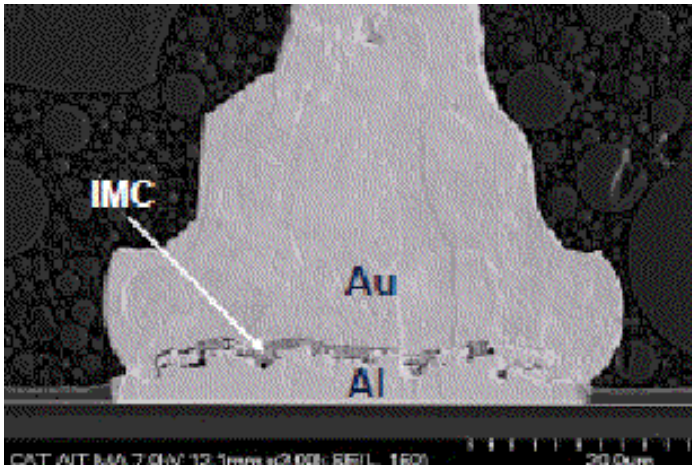

# Long Term Reliability - Delamination

- **Delamination**
  - Delamination can occur rapidly during soldering if excessive amounts of moisture were absorbed by the mold compound resulting in popcorning fractures or interfacial fractures during soldering.
  - Delamination can also occur slowly because of swelling from gradual absorption of moisture while in service or thermal expansion mismatch stresses.
    - Delamination can cause fractured or lifted wire bonds that result in open circuits.
    - It can result in cracks in the package that can allow contaminants to enter, leading to corrosion of copper wires or bond pads that results in open circuits
    - Can cause current leakage due to the presence of mobile ions.

Scanning Acoustic Microscope Image of IC internal delamination sites shown in red.

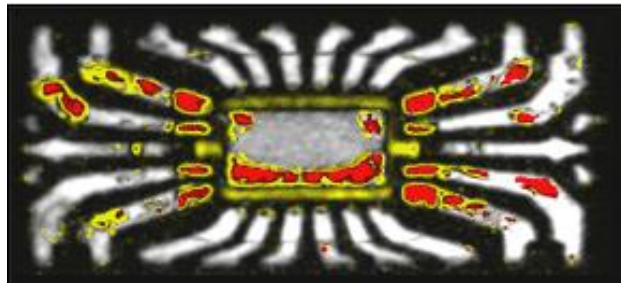

SIOC Package

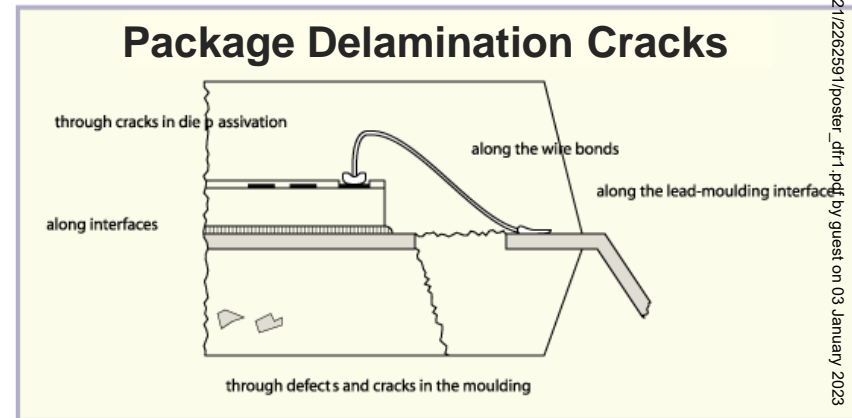

# Long Term Reliability - Delamination

- Delamination Prevention
  - Prevention of Solder (popcorning) delamination requires strict adherence to the IC manufacturer's Moisture Sensitivity Level (MSL) Rating

Category	Allowable Time
MSL 1	Unlimited, not sensitive
MSL 2	1 year
MSL 2A	4 weeks
MSL 3	1 week
MSL 4	3 days
MSL 5	2 days
MSL 5A	1 day
MSL 6	Must bake

- Delamination over time requires the use of moisture barriers such as conformal coating.

# Long Term Reliability – Cu-WB Corrosion

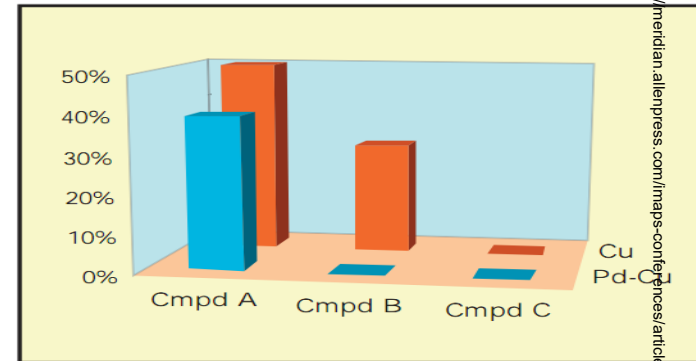

- Autoclave conditions have been found to cause Cu-WB bond separation failure of Cu wire bonds in some over molded packages.
- High Ph & Cl content in the molding compound was a corrosion activator triggering galvanic corrosion between the IMC and the Al pad
- Humidity, temperature & electrical bias drive this failure mechanism.
- When a forward bias is applied, Cl<sup>-</sup> ions are attracted to the positively charged pad causing corrosion that eventually result in bond separation.
- Mechanism is accelerated by the high humidity and temperature conditions automotive electronics are required to endure.
- Using a molding compound with a low pH (4-6) and a low chlorine content <20ppm, (preferably <10ppm) is essential for alleviating corrosion failure risks
- Also important to minimize voids or irregularities in CuAl IMC bonds that would allow moisture ingress that could hasten corrosion degradation and separation stresses within the bond.

# Long Term Reliability - Elevated Temperature Endurance - CU-WBs Clearly Better

- Au-AL and Cu-AL intermetallics continue to grow over time at a rate proportional to elevated temperatures.
  - Excessive Intermetallics can lead to electrical or mechanical failure
- Cu-AL intermetallics grow at a much slower rate than Au-AL
- Molding compound has little effect

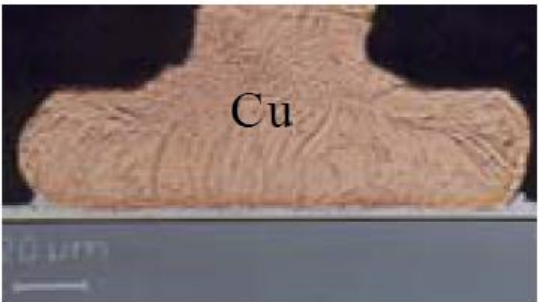

**Intermetallic Penetration - AlSi-Cu Bond**  
(aged 800 hours at 180°C)

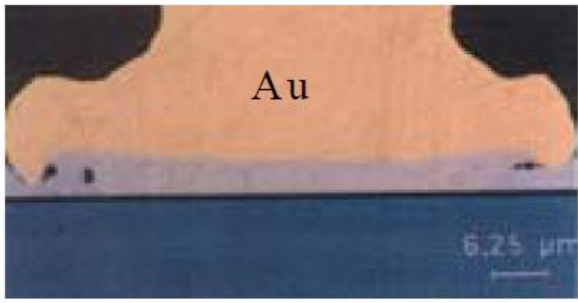

**Intermetallic Penetration - AlSi-Au Bond**  
(aged 200 hours at 200°C)

L Levine, Update on High Volume Copper Ball Bonding

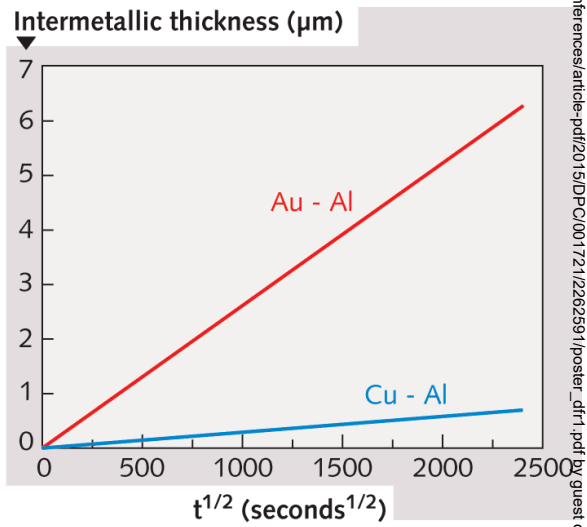

C. Breach, The Great Debate: Copper vs. Gold Ball Bonding

# Wire Bond Pull Strength After Time at Elevated Temperatures

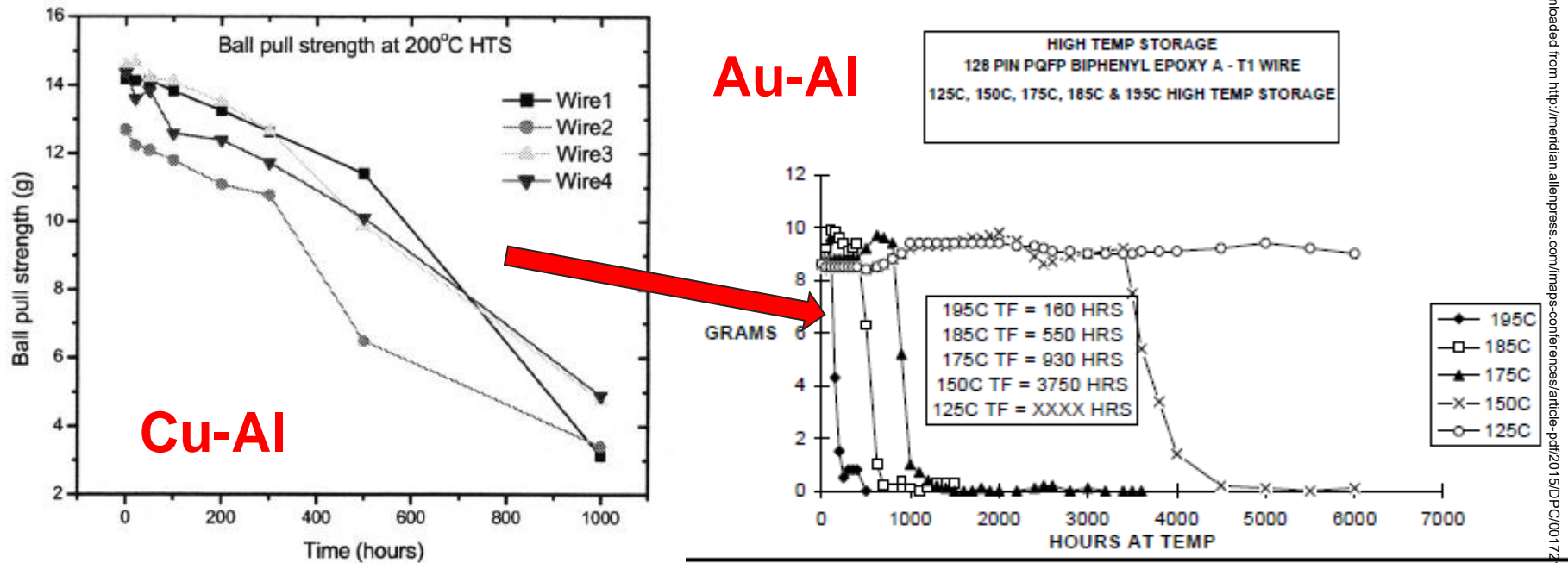
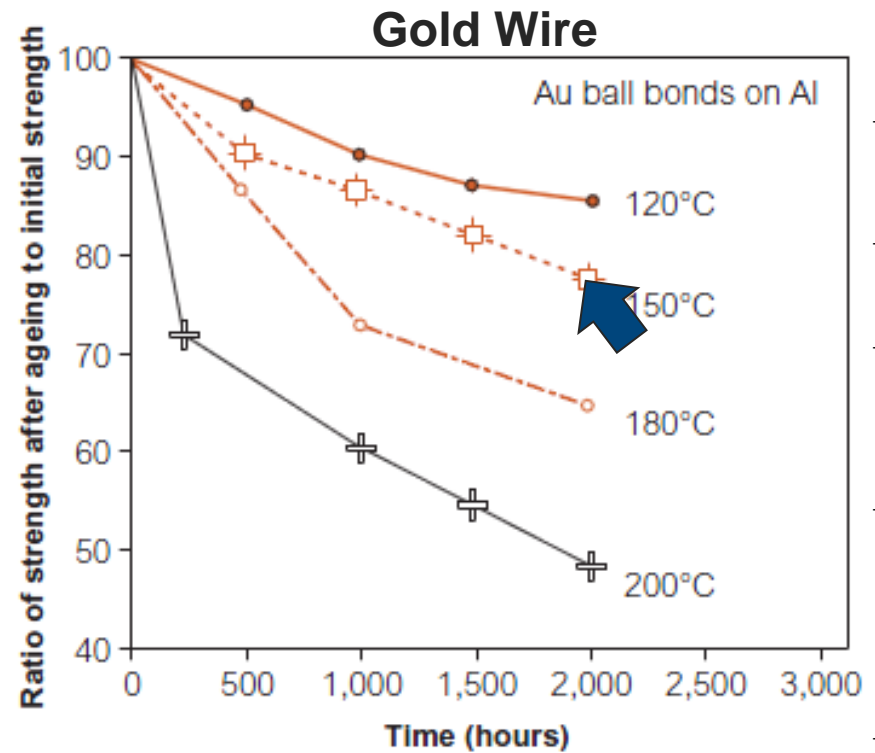
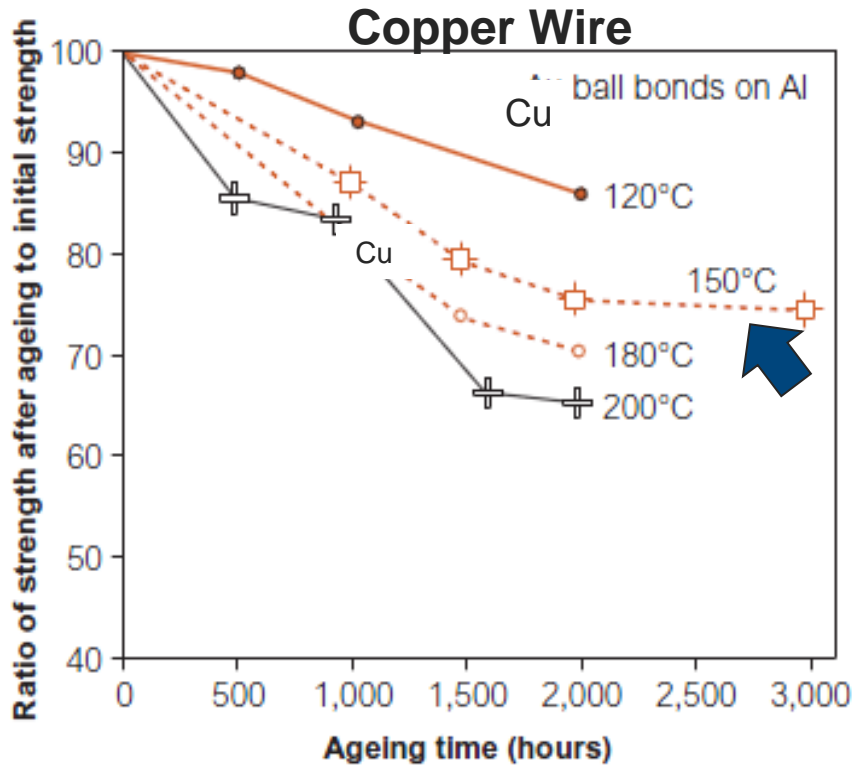

Figure 6. Ball Pull Strength after HTS at 200°C

- **Cu-Al shows improved pull strength over Au-Al at 200C**
  - Different failure mode (gradual vs. sudden)
  - 200C is beyond most automotive temperature ranges but a concern for other application especially down hole oil dripping electronics.

# Shear Strength after time at Elevated Temperatures



Shear strength of Au and Cu ball bonds on Al pads.  
 At lower temperatures (<150C) they are similar in strength loss.

J. Onuki, M. Koizumi, I. Araki. IEEE Trans. On Comp. Hybrids & Manfg. Tech.  
 12 (1987) 550

# Automotive Electronic Council – New Qual Spec for Cu-WB ICs

- AEC Q006 under development - Completion Goal is May 2015
  - Additional requirements for Cu-WB over and above what is specified in AEC-Q100 and AEC-Q101
- OEM originally wanted a PCB mounted thermal cycle test.
  - Difficult to spec since PCB CTE widely varies with wide range of PCB materials and amount of copper in the board layers (i.e. no common industry standard reference PCB available)
  - PCB Thermal Cycling option remains
    - “As Agreed To and Specified To Between User & Supplier”
  - Q0006 Spec workgroup now working on details of Sample size, Stress Levels & Test Duration . . .
- Features an appendix of Failure Mechanism & DfR Best Practice

# Summary

- Cu-WBs have been proven to provide real cost savings
- Advances in Cu wire and machine technology is helpful in hitting the smaller process window
- Maintaining quality through strict control of variables is challenging requiring extreme due diligence
- Reliability of Cu-WB in consumer grade semiconductor is going well due to continuous improvement optimization efforts since 2010
- New challenges & optimization needs being discovered as Cu-WBs migrate into automotive E/E, the first of HI-REL, Long Life, Harsh Environment E/E Application (Defense, Aviation, Infrastructure . . . Etc.)
  - All consumer grade Cu-WB solutions may not be suitable for Automotive and other HI-REL applications.
  - More Optimization R&D is underway

# Lessons Learned Summary

## – Critical to QRD Characteristics for Automotive Cu-WBs

- Use Forming Gas 95% Nitrogen+5% Hydrogen Atmosphere to prevent Cu oxidation
- Optimized thermosonic bonding process so that  $\geq 0.2\mu\text{m}$  of the original aluminum pad thickness remains, to maintain strength needed to prevent pad fractures & craters
  - May require pads that are thicker than the typical  $1\mu\text{m}$  Al thickness used with gold WBs
  - High purity Copper wire ( $>95\%$  Cu) is softer, less abrasive
- Best QRD achieved with wire bonders develop for Cu-WB,
  - QRD will be lower with Retrofitted Gold WBs
- Essential that the CuAl intermetallic area cover at least 70% of the ball contact area.

# Lessons Learned Summary

## – Critical to QRD Characteristics for Automotive Cu-WBs

- Capillary Tips w/Larger Dia. & face Angles keyed to Wire Diameter Produce Larger, Stronger, More Durable Wedge Bonds.
  - May need to consider IPC like Class 1-3 rating for Cu-WB, more info need to develop
- Adherence to component Moisture Sensitivity Level (MSL) Rating needed to prevent delamination during soldering.
- To prevent corrosion:
  - Use a molding compound with a low pH (4-6) & Chlorine <20 ppm, (preferably <10 ppm)
  - Use a bonding process that minimize voids or irregularities in CuAl IMC bonds that would allow moisture ingress that could hasten corrosion degradation and separation stresses within the bond.